

ABATE OF FLORIDA, INC. PALM BEACH CHAPTER



THE **Chrome Chronicles**



ISSUE 172 2019-12 PALMBEACH.ABATEFLORIDA.COM DEC. 2019



**A MERICAN
B IKERS
A IMING
T OWARD
E DUCATION**

**NEXT CHAPTER
MEETING
11:30 AM
2ND Sunday
Dec. 8**

**CHECK TWICE
FOR MOTORCYCLES**

**LET THOSE
WHO RIDE
DECIDE!**



**ABATE of FLORIDA, Inc
Palm Beach Chapter**

MOTORCYCLE RIGHTS PARTY

**Dec. 15, 2-6 pm @ Lakeside Anchor Inn
2412 Floral Rd, Lantana, FL 33462 Hypoluxo west of I95**

\$3 per person / \$5 per couple

Everyone is invited - Rain or Shine

50/50 RAFFLE - LIVE MUSIC - FOOD & DRINKS

DOOR PRIZE @ 4PM SHARP

(MINIMUM \$200/MAXIMUM \$500)

Door prize will be equal to \$1 per head for every person with paid admission, with more people the prize increases so bring all your friends and have a great time after the Toy Run

Safety and Membership Table onsite

Proceeds support our continuing legislative efforts in Tallahassee

For more information, contact LB @ 561-907-0043

<http://palmbeach.abateflorida.com>

ABATE of Florida, Inc., does not condone drinking and riding. Donations to ABATE of Florida, Inc., are not deductible for federal income tax purposes. A copy of the official registration and financial information may be obtained from the Division of Consumer Services by calling toll-free within the state. Registration does not imply endorsement, approval or recommendation by the state.

2019-2020 Board of Directors & Trustees

PRESIDENT	Curtis "Harpo" Alva	561-371-6176
VICE PRESIDENT	John "LB" Valiquette	561-907-0043
SECRETARY	Florie "Half Pint" Wilcox	561-762-6119
TREASURER	Suzanne "SushiQ" Seguin	786-574-1344
SERGEANT-AT-ARMS	"Petee" Carroll	561-284-1719
MEMBERSHIP TRUSTEE	Suzanne "SushiQ" Seguin	786-574-1344
MEMBERSHIP ASSISTANT	Harold "Whistler" Walters	954-260-9681
SAFETY DIRECTOR	Dan "Slo Motion" Henderson	561-702-9929
LEGISLATIVE	Dan "Slo Motion" Henderson	561-702-9929
LEGISLATIVE ASSISTANT	Amanda Stout	305-772-2618
STATE DELEGATE	Dan "Slo Motion" Henderson	561-702-9929
STATE DELEGATE	Ken "Snooze" Gerecke	561-389-6546
NEWSLETTER/WEBMASTER	Dan "Slo Mo" Henderson	561-702-9929
PR/COMM TRUSTEE	Dan "Slo Mo" Henderson	561-702-9929
PRODUCTS TRUSTEE	Vacant	

Our Email is palmbeach.abateflorida@gmail.com

Put in the subject: ABATE and the officer to whom should see it and what about to so that message is directed right

Mailing Address

ABATE - Palm Beach Chapter
P.O. Box 530944
Lake Park, FL 33403

DISCLAIMER

This official publication of ABATE of Florida, Inc., Palm Beach Chapter accepts no responsibility for the comments, advertisers or opinions contained in this publication. The submission deadline for all material for publication is after the third weekend of month or earlier for on time completion.

IDENTIFICATION STATEMENT

This newsletter is the monthly publication of ABATE of Florida, Inc. Palm Beach Chapter published monthly 12 times a year
ABATE of Florida Inc
Palm Beach Chapter
P.O. Box 530944
Lake Park, FL 33403

ABATE of Florida, Inc. does not condone drinking and driving

DONATIONS TO ABATE OF FLORIDA, INC. ARE NOT DEDUCTIBLE FOR FEDERAL INCOME TAX PURPOSES

A copy of the Official Registration and Financial Information may be obtained from the Division of Consumer Services by calling toll-free within the State. Registration does not imply endorsement, approval, nor recommendation by the State.

WWW.800.HELPFLA.COM 1-800-435-7352



President's Message

Curtis Alva

EDITORIAL GUIDELINES

You are encouraged to submit letters about ABATE related to events, articles, photographs, commentaries, etc. Please do not submit slanderous nor accusing letters, profanity nor nudity. Abate of Florida, Inc., will not accept any advertising that discriminates against any type of motorcyclist

We had a great November and are looking to a great December. ABATE worked with the Boca Raton Ward of the LDS Church on the Turkey Toy Run on November 23rd. This was the second year for this toy run and ABATE Palm Beach members rode to Boca with American Legion Riders, where we joined with an enthusiastic crowd of club members and independents. We were fed a hot, home-made breakfast and participated in a fine ceremony honoring veterans. Then we rode to Royal Palm to the Kids Cancer Center to deliver a sleigh full of toys to the children. The kids came out front to greet the bikes as we arrived and then we handed the toys to the children, who put them to good use immediately. It was an extra blessing to be able to see the joy in the faces and hear the laughter in their voices. Then we feasted on burgers and pizza. Because of ABATE's support for the ride, yours truly was honored to be selected to ride in the front row, with Jason Gilmore, another ABATE member and the founder of the ride.

For December, there are many fine events coming up, including the Bill's Bikes Toy Run on December 15. As we have for as long as anyone can remember, ABATE Palm Beach will be sharing that date with the Toy Run and our annual party will be held at the Lakeside Anchor Inn, in Lantana, starting this year at 2 p.m., to give everyone time to participate in the Toy Run. And, for the first time, this year we will be giving away a huge door prize. The door prize will be equal \$1 for every paid admission to our party, with a \$200 minimum and a \$500 maximum. So come to our party and bring your friends and lets get that door prize up to \$500!!! The door prize drawing will be at 4 p.m., sharp.



Find us on
Facebook

<https://www.facebook.com/AbatePalmBeachChapter>

UPCOMING Event Schedule

Sun. Dec 1 Southernmost ABATE Keys Toy Run / Polk ABATE Toy Run

Monday Dec. 2. Skulls MC Open House

Wed Dec. 4 - Gorilla Bob's Island Jack's, and Pirates Well Lake Park Bike Nights

Thurs. Dec. 5 - Abacoa Bike Night PB Harley 7-10, Black Piston's Open House, Howley's Bike Night

Sat. Dec. 7 SFPC Toys in The Sun Run 11:30-11pm Pompano Bch Amphitheater 1806 NE 6th

2ND Sunday Dec. 8 — Palm Beach Chapter Meeting ABATE of FL. Inc. 11:30 am V.F.W. Post 4143 located at 2404 Broadway, Riviera Beach 561-844-5718. From I 95 exit Blue Heron Blvd. go east to Broadway (Federal Hwy., US- 1) turn right, go south 1 block the V.F.W. is on the east side. Look for the flag. Breakfast will be served 9:00 AM 'til Noon

Tuesday Dec. 10 - Lone Legion Open House

Wed Dec. 11 - Gorilla Bob's Island Jack's, and Pirates Well Lake Park Bike Nights

Thurs. Dec. 12 Vintage Iron Bike Night

Friday Dec. 13 AOA WPB Open House

Dec. 14 Wreaths Across America at South Florida National Cemetery, 441/7 Lake Worth. Ceremony starts at 12:00 PM

Dec. 14 ABATE of FL Inc State Meeting Ocala

Sunday Dec. 15 Bill's Bikes Toy Run early

Sunday Dec. 15 ABATE PB Annual at Anchor Inn 2-6

Wed Dec. 18 - Gorilla Bob's Island Jack's, and Pirates Well Lake Park Bike Nights , States MC Lake Worth Open House 3570 Boutwell Rd. Lake Worth

Friday Dec. 20 AOA North Open House

Wed Dec. 25 - Gorilla Bob's Island Jack's, and Pirates Well Lake Park Bike Nights

Thurs. Dec. 26 - Turboz Custom Cycles Bike Night 7-10 PM Ralph's Stand Up Bar Jupiter

REMINDER: EVERY

Wed Nights Gorilla Motors/PBH Bike Night at Island Jack's,

Sat. night Fly n Wheels Open House

PLEASE ATTEND THE OPEN HOUSES FOR A GOOD TIME AND SHOW OF SUPPORT WHEN POSSIBLE



ABATE of FLORIDA, Inc Palm Beach Chapter

MOTORCYCLE RIGHTS PARTY

Dec. 15, 2-6 pm @ Lakeside Anchor Inn
2412 Floral Rd, Lantana, FL 33462 Hypoluxo west of I95

\$3 per person / \$5 per couple

Everyone is invited - Rain or Shine

50/50 RAFFLE - LIVE MUSIC - FOOD & DRINKS

DOOR PRIZE @ 4PM SHARP

(MINIMUM \$200/MAXIMUM \$500)

Door prize will be equal to \$1 per head for every person with paid admission, with more people the prize increases so bring all your friends and have a great time after the Toy Run

Safety and Membership Table onsite

Proceeds support our continuing legislative efforts in Tallahassee

For more information, contact LB @ 561-907-0043

<http://palmbeach.abateflorida.com>

ABATE of Florida, Inc., does not condone drinking and riding. Donations to ABATE of Florida, Inc., are not deductible for federal income tax purposes. A copy of the official registration and financial information may be obtained from the Division of Consumer Services by calling toll-free within the state. Registration does not imply endorsement, approval or recommendation by the state.

ABATE of Florida, Inc. Mission Statement

WHO WE ARE

We are a non-profit organization of motorcycle enthusiasts from all walks of life. We lobby and educate the government and the general public to promote motorcycling in a safe and positive image. We endeavor to enlist the cooperation and participation of all organizations and individuals that share a similar interest in preserving our American tradition of FREEDOM. We promote motorcycle safety, training, & political awareness. We ARE NOT A CLUB NOR A GANG. We fund our work through events, toy runs, poker runs, campouts, and other motorcycle activities. We are your neighbors & friends who work, pay taxes, and get involved with our community. We serve and support our country and believe in freedom. We use all legal means to protect our rights without infringing on the rights of others. We are Pro-choice NOT anti-helmet, it is up to you to decide.

OUR GOALS

To become a powerful and viable political force in legislative matters concerning the motorcyclist.
To promote the safe riding habits without infringing on individual freedoms.
To motivate the bikers to write letters to legislators before, during, and after the legislative session.
To furnish a newsletter to keep all bikers informed in regards to upcoming legislation.

MEMBERSHIP

When you become a member of ABATE OF FLORIDA, INC. you are helping make a difference in the ongoing mission to protect your right to ride and enjoy the motorcycle of your choice, your choice of riding apparel, and when and where you can ride a motorcycle. These are issues that are real and present in today's "protect yourself from yourself" political environment. This holds true for all levels of government. There will always be those who see our love for motorcycling as a negative and will try any means to control and if possible prohibit motorcycle use.

On the local level our members get out the vote and support candidates who are sympathetic to our issues. We also will endeavor to lobby local governments whenever there are issues that need to be addressed, affecting local motorcycle use, ownership, and any discrimination that may result from said use of ownership.

At the state level we have a paid registered lobbyist who regularly visits our state capital in Tallahassee to lobby our legislators on the issues concerning the motorcycling public in Florida. He also finds reliable House and Senate sponsors for the bills we support. On the national level we are aligned with Motorcycle Riders Foundations (MRF), and the National Coalition of Motorcyclists (NCOM), along with several other international motorcycle rights organizations (MRO's).

As one can see we have our ear to the ground and our resolve tempered like steel. As Americans we have had it demonstrated to us time and again the vigilance is armor of free men and women. We shall not let the armor rust or weaken. With your support we can re-enforce and strengthen the armor for now and generations to come.

What else do you get with your membership? All members receive with their paid membership, the Membership Card, Event Discounts and Updates, Voting Privileges, Free Newsletter Classified Advertisements, a Chapter Newsletter, and a free \$4,000 Accidental Death or Dismemberment Insurance Policy from the American Income Life Insurance Company.

Memberships are open to anyone 18 years of age or older, no matter what type of motorcycle you ride, if any at all! We welcome all riders—in clubs, associations, independents, and sport riders to join us.



Prototype model shown. Production model features will vary. Not yet available for sale. All future models shown may not be available in all markets. Introducing the Harley-Davidson® Bronx™. Unapologetic attitude with the performance necessary to back it up. Torque, handling, and technology in a modern package. Middleweight has a new meaning.
<https://www.harley-davidson.com/us/en/motorcycles/future-vehicles/bronx.html>

LIVEWIRE HAS ARRIVED

Meanwhile the Livewire, the delayed Harley's electric motorcycle, has made it to the market. I saw these at the St Pete Bikefest at Bert's Barracuda Harley. Here they are charging.

Both of these new models have a sport bike look, not seen since the Buell.



New electric motorcycle patent shows BMW working on radical electric sport bike

Micah Toll - Nov. 25th 2 @MicahToll

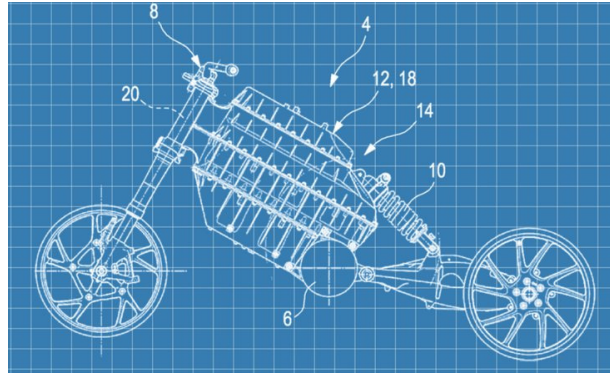

BMW may be getting closer to unveiling an impressive new electric sportbike that could rival the likes of the Zero SR/F and Energica's Ego. At least that's what these recent BMW electric motorcycle patent drawings seem to indicate.

The patent drawings from BMW show an electric sport bike with an unconventional design.

Unlike most motorcycles, which are built on a standard frame, BMW's patent drawings show a frameless motorcycle design.

Instead, the major structural component is a sealed box containing the batteries and controller.

The head tube of the bike is mounted fore of the

battery box, while the motor is mounted just below and aft of the box.

The swingarm mount appears to be mounted to the motor assembly, which would keep the swingarm pivot and the motor axle as close to each other as possible, simplifying chain or belt tensioning.

The design may be novel as far as electric motorcycles are concerned, but it isn't entirely new to BMW.

The BMW C Evolution electric scooter actually adopts a similar design, with a sealed battery box serving as a structural member in lieu of a typical frame. The C Evolution is a five-year-old design at this point, though it has undergone a number of design improvements over the years.

BMW has played with far-out electric motorcycle concepts in the past, such as its Vision DC Roadster electric motorcycle concept, though the motorcycle seen in these new patent drawings looks much more like something the company could actually manufacture — and soon.

BMW Vision DC Roadster concept

Could this be a high-performance BMW electric motorcycle?

Yes, it appears likely that this could be a high-performance BMW electric motorcycle — something that could presumably compete with the Zero SR/F and the Energica Ego.

BMW is no stranger to sport bikes, of course. And the electric motorcycle seen in these patent drawings appears to line up well against the BMW F800 with nearly identical geometry, handlebars suspension linkage, and even the same wheels.

The next question will of course be, "How much does it cost?"

The BMW C Evolution electric scooter isn't cheap, though its high performance figures and BMW badge help it sell well, even with a price of around \$14,000. The C Evolution has a top speed of 129 km/h (80 mph) and a range of 159 km (99 miles), thanks to its 12.7 kWh BMW i-series battery module. And that's with just a 35 kW (48 hp) motor.



If the electric motorcycle seen in this patent could pump up those figures into true sport bike numbers, the motorcycle could easily command a price in line with the \$18k-\$22k range of Zero and Energica's sport bikes.

But until BMW gives us more info, any speculation about the price is simply that — speculation.

Electrek's Take This is exciting news! Another legacy manufacturer getting into high-performance electric motorcycles!

As much as everyone likes to dump on Harley-Davidson as if it was a competitive sport, the company should be commended for being the first big motorcycle manufacturer to enter the electric market. I believe that it is at least in part due to that brave move that we are now seeing large companies like BMW and Kawasaki making their own in roads into high-performance electric motorcycles (even if Kawasaki's electric sport bike specs are kind of embarrassing).

This BMW electric sport bike could be a force to be reckoned with. And with BMW's design chops, it could look the part, too.

I'd recommend keeping an eye out for whatever BMW is working on here, because this looks very promising.

<https://www.electrek.co/2019/11/25/bmw-electric-motorcycle-patent-electric-sport-bike/>

BMW's motorcycle division puts its new flat-twin in a gorgeous concept

Ronan Glon

BMW's Motorrad division unveiled a follow-up to the R18 concept presented earlier in 2019 at the annual EICMA show. Named R18/2 (pronounced "slash-two," according to the brand), it receives the same flat-twin engine as the first R18 but wears a design that's more athletic and less polished.

When they put their pencil to the paper, stylists set out to create the exact opposite of the R18 concept that basked under the Italian sun last spring. The R18/2 concept wears the long, drawn-out proportions of a performance cruiser, while incorporating a handful of retro-inspired styling cues that link BMW's past to its future. Candy Apple Red paint applied to the body panels helps the bike stand out in a crowd, but designers made it a point to proudly keep the big flat-twin in plain view.

One of the challenges of designing a motorcycle is that nearly every mechanical part is visible, so the drivetrain has to blend form and function. This is far less of a worry for car designers. To that end, the crankcase and cylinder heads were shaped with an eye on the 1960s, and the new engine received a two-tone paint job to emphasize its flat layout. Everything inside is modern, however. Full technical specifications remain vague, but the twin is an air-/oil-cooled 1.8-liter unit. It spins the rear wheel via a chromed universal shaft, a feature rarely seen on a modern motorcycle. Most bikes sold new in 2019 use a belt or a chain to convert horsepower into forward motion.

BMW strongly hinted the original R18 concept previewed a production model. Here again, the manufacturer dropped hints that the R18/2 could reach production sooner rather than later.

"I have to admit: We were very impressed at how it was possible to bring this boxer concept forward from the 1930s, via the 1980s, into the 2020s," explained Bart Janssen Groesbeek, BMW Motorrad's designer for Big Boxer concepts. We expect to see the German firm's new flat-twin in showrooms by the end of 2020, but time will tell whether it's in the R18, the R18/2, or something else entirely.

BMW's motorcycle division puts its new flat-twin in a gorgeous concept originally appeared on Autoblog on Fri, 8 Nov 2019 09:46:00 EST. Please see our terms for use of feeds.

<https://www.msn.com/en-us/autos/motorcycles/bmws-motorcycle-division-puts-its-new-flat-twin-in-a-gorgeous-concept/ar-BBWtcwu>

**Advertisers
Online**

Tell them you saw ad in
Palm Beach ABATE
Newsletter!

We need help in getting more
advertisers to support the
production of our newsletter.
Our rates are great so spread
the word so can continue to
expand distribution to the
general public and riders

Printed copies can be picked up
at meeting and events table

Free Monthly business card ad
for a member Send in scan of
card or better, bring to Chapter
meeting

We Need more advertisers
to be able to print more
copies

Please Pay for your
Event to be Included
and Support us

ABATE of Florida, Inc.

Palm Beach Chapter Newsletter Advertising

Newsletter is accessible on palmbeach.abateflorida.com in FULL color
with active links including those of advertisers. It is also printed in
black & white in an 8 by 11 format for distribution at various places.

Newsletter Ad Rates 6.5% sales Tax included

SIZE	1 MONTH	3 MONTHS	6 MONTHS	YEAR
BUSINESS CARD	\$ 12.72	\$ 26.71	\$ 49.61	\$ 89.29
QUARTER PAGE	\$ 25.44	\$ 50.88	\$ 92.86	\$ 167.14
HALF PAGE	\$ 38.16	\$ 78.86	\$ 146.28	\$ 263.33
FULL PAGE	\$ 50.88	\$ 125.93	\$ 232.78	\$ 418.99

Contact: _____ DATE _____

Size and Duration of AD: _____

Business Name: _____

Address: _____

Phone : _____ Email: _____

Business Web Site _____

Material for ads should be in digital format such a JPG or PDF emailed to
palmbeach.abateflorida@gmail.com
and send in by the 3rd weekend of the month to insure inclusion for next
issue

Fill out form, print, sign attach your check or money order and mail to:

ABATE - Palm Beach Chapter
P.O. Box 530944
Lake Park, FL 33403

OUR NEWSLETTERS are best viewed at palmbeach.abateflorida.com as most timely (by the first of month), in full color, and with active Internet links to stories, etc., of interest. And for us with older eyes, can be zoomed in without magnifying glasses. We do need our advertisers, donations and more members to be able print and distribute more copies to the county for motorcyclists to be aware of the issues facing us. So please join in and let us know of good places to put them in. Issues can be mailed to members if no Internet access. Non-members can buy a subscription for \$20 a year but the other two methods are faster as it takes more time and cost to get mailings done.

Blackstone HyperTek electric motorcycle smashes all molds Better than the Tron Lightcycle and Akira bike because it's real.



Blackstone Tek HyperTek E-Moto Blackstone By Jonathon Ramsey

Here we have a motorcycle that takes advantage of what can be done with an electric powertrain and looks like one of the possibilities in the sci-fi futures we've dreamed of. South African company Blackstone Tek, better known by the initials BST, is known for its carbon fiber motorcycle and car wheels. When Founder Gary Turner decided he wanted to build an electric bike, he enlisted fellow South African designer Pierre Terblanche, who's designed two-wheelers like the Ducati 749, 888, 999 and Hypermotard, and the Confederate X132 Hellcat Speedster. The result of the collaboration is this, the HyperTek. It will be hand-built, limited-edition, and expensive.

The HyperTek's mechanicals hang from a one-piece carbon fiber monocoque and billet sub-frame. The water-cooled, DHX Hawk motor produces 105 hp and 88.5 pound-feet of torque, powered by a 4.75-kWh battery. BST claims the battery can be fully recharged in 30 minutes on a fast charger, with a range of 186 miles on a charge. That's almost certainly on the more generous European standard, and we suspect the range claim includes the supplemental battery pack; a Zero S motorcycle, for instance, packs a 7.2-kWh battery and lists an 89-mile range in city riding. On the HyperTek, the standard pack sits inside the metal box ahead of the frame. The gray box of the supplemental battery can be seen in a couple of photos hanging underneath that, featuring a cell pattern along the front, otherwise replaced with green, logoed fairings.

The custom front end molds the triple clamp and down tubes in a single piece of carbon fiber. The front suspension was inspired by the Horst Leitner unit on an ATK motorcycle, the rear suspension is a mono-shock slipped inside a single-sided swingarm akin to that on the Terblanche-designed Moto Guzzi V12 concept from 2009. The package sits on BST's 17-inch Rapid Tek wheels with a wheelbase of 58 inches, and the bike weighs 450 pounds.

There's no cockpit instrumentation. Riding vitals are instead beamed to a heads-up display inside the Cross X1 helmet. The HUD shows a rear-view camera image, too. Another novelty is the electronically modulated clutch that enables revving, burnouts and wheelies thanks to "Wheelie & Traction

Control." Cruise control eases the highway miles, hill stop eases inclined launches, and a built-in sound generator gets attention in urban environments.

Bike EXIF says BST wants to start production on the HyperTek in 18 months, and each example will cost \$80,000. Those are steep numbers, but HyperTek's design, technology and

pedigreed backers convince us to say Yes."

<https://www.engadget.com/2019/11/19/blackstone-hypertek-electric-motorcycle-smashes-all-molds/>

<https://www.autoblog.com/2019/11/18/blackstone-hypertek-electric-motorcycle/>



1923 Indian motorcycle with sidecar and claimed Steve McQueen ownership



The 1923 Indian is from the first model year of the large-displacement Big Chief. The Pick of the Day is a vintage bike not only owned by the late actor but restored by another cultural icon, Von Dutch, the seller says. A 1923 Indian Big Chief motorcycle is a big deal on its own, but add in the impeccable celebrity provenance of Steve McQueen ownership and a Von Dutch restoration, and you wind up with something special indeed.

That particular item is advertised on ClassicCars.com by a dealer in Auburn Hills, Michigan, a 1,200cc V-twin Big Chief equipped with a Princess sidecar that belonged to the late actor, according to the seller.

"Not only was it owned by Steve McQueen, but it was additionally restored at his request by renowned artist Kenny Howard, known by those in the custom-car and motorcycle world as Von Dutch," the ad says.

The Big Chief debuted in 1923 as Indian upped its game with a big-displacement engine and more features. It quickly became Indian's best-selling model and propelled the Massachusetts company to become the largest motorcycle manufacturer in the world.

But the intrinsic value of this highly desirable vintage motorcycle pales compared with the aura created by the McQueen effect, which makes just about anything that he once owned, drove or sat in become enormously valuable.

The Von Dutch restoration adds quite a bit to the allure. His business card with “for Steve McQueen” hand-written on it is laminated inside the sidecar, offering validity of the relationship. The seller does not mention other documentation in the ad, so a prospective buyer would need to ask.

“In 1969, McQueen turned to the best in the business of car-culture art and motorcycle mechanicals when it came time to restore this iconic first-year Indian Big Chief,” the seller says. “Von Dutch was a highly influential Southern California-based artist, fabricator, mechanic and restorer.

“The mechanical side of the restoration began with the 1,200cc (74 CI) Indian dual-cam V-twin, and worked its way out to the paint, lettering and pinstriping laid down by Von Dutch himself.”



The Indian looks to be in great condition, mated with the correct type sidecar, and it’s a “rideable and enduring symbol of the dedication and creativity of people that embrace motorcycling with passion,” the seller adds.

Mix a highly desirable motorcycle with a pair of pop-culture icons, and the value rockets far above what the books say it’s worth. The seller is apparently counting on the McQueen effect as the asking price is a resounding \$199,000.

To view this listing on ClassicCars.com, see Pick of the Day.

<https://journal.classiccars.com/2019/11/22/1923-indian-motorcycle-with-sidecar-and-claimed-steve-mcqueen-ownership/>



BIKER BUCKET LIST

What's on your bucket list - Sturgis, rallies, races? For me it is motorcycle museums. It was probably started when I saw the Guggenheim Art of the Motorcycle exhibit in Orlando in 2006. That was great, it even inspired the Barber Motorcycle Museum. There are many I want to see but I think I've done the best -twice. It should be on all biker lists! Barber Motorsports Park is an 880-acre multi-purpose racing facility located in Birmingham, Alabama. It was built by Alabama native George W. Barber, and includes the 230,000-square-foot Barber Vintage Motorsport Museum. Address: 6040 Barber Motorsports Pkwy, Leeds, AL.

Back in June 2010 after attending an ABATE state meeting in north Florida, I took a trip to visit two bike museums. First was the Art in Motion Museum in Warm Springs GA. It was an interesting little "village" but it has since closed. Then I was off to Alabama for the amazing Barber Motorsports. They have five floors of bikes! I thought it would take days to tour, but as I went through was able to do in a day. This last October before the State meeting in Pensacola I return to Barber. It doubled in size with a new wing, up to 5,000 bikes on display, and new landscaping in the race way. Here are some photos from last trip.

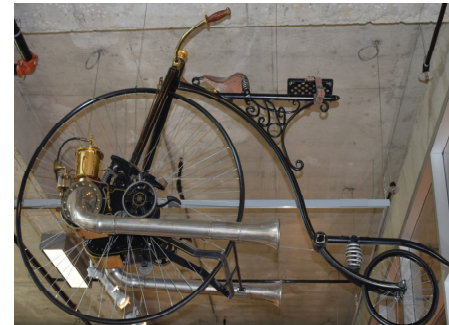

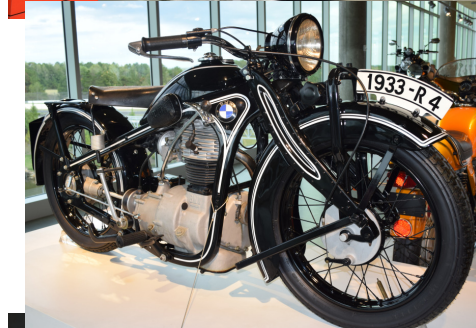

WEEKLY EVENTS

Mon Dinner 6:30 States MC
Pompano Clubhouse
3rd or 4th Mon Skulls MC Open
House LLB clubhouse

Once a Month Tues Lone Legion
MC Brotherhood Open House
2nd Tues Jupiter Moose Bike Night

3rd Wed States MC Lake Worth
Open House 8pm

Wed Island Jack's Bike Night with
Gorilla Motors

Wed Chit Chat's bike night 7pm
Free BBQ, music

Wed Pirates Well Bike Night
9477 Alt. A1A Lake Park

Last Wed Gatti's Garage Bike
Night 130 South H St Lake Worth

Usually 1st Thurs Black Pistons
MC WPB Open House

1st Thurs PBH Abacoa Bike Night

1st Thurs. Howley's Bike Night
4700 S Dixie WPB

2nd Thurs TBS Bike Night
Tequesta

3rd Thursday Palm Beach and
Treasure Coast Harley Bike Nights

Last Thurs Turboz/Ralph's Bike
Night Jupiter

1st Fri Enforcers MC Party
Fri Twice a Month AOA MC WPB
Open Houses

SAT HOG Morning Palm Beach
Harley and often other events and
bikini bike washes Grill Days
SAT night Fly n Wheels Open
House

States MC Lake Worth
Open House
Wed
7pm-12am
Food is Always Complimentary
Independent Bikers and
Friends
are Welcomed
3570 Boutwell Rd. Lake Worth

Black Pistons
MC
BLACK PISTONS MC
WEST PALM BEACH
Come join us for our open house
Thursday First
7:30pm-?

BIKE NIGHT
HARLEY-DAVIDSON
COMPANY
GORILLA
MOTORS
WED. 6-9PM
\$0.75 WINGS
6PM - 10PM
\$2 DRAFTS
10PM - CLOSE
\$5 JACK DANIELS
\$2 BOTTLES
BUD LIGHT
MILLER LIGHT
GUINNESS

Food, Drinks, Brotherhood
7:30p.m til-? @
2950 Commerce Park Dr.
Boynton Beach, FL 33426
No Attitudes, No Problems.

BIKE NIGHT
& Craft Beers
Last Wednesday of Each Month
6pm-10pm
BEER SPECIALS • FOOD TRUCK
130 South H St Lake Worth

LOST WEEKENDS VINTAGE
MOTORCYCLE NIGHTS
TUNE UP THESE 25 YEAR OR OLDER MOTOS
& RIDE THEM OUT EACH 2ND THURSDAY OF THE
MONTH TO LOST WEEKENDS VINTAGE
FREE PARKING
FREE T-TEES
MILEAGE
VINTAGE TIRE GAMES
COCKTAILS
SPONSORED BY:
ACES HIGH
TREASURE COAST
INDIA MOTORCYCLE
POWER SPORTS

Pirates Well
Restaurant and Bar
WEDNESDAY, 7-11
ALL YOU CAN EAT WINGS!
\$3 CAPTAIN • \$4 TIGER • \$7 DOMESTIC PITCHERS &
\$12 DOMESTIC BUCKETS (6)
RAFFLES PRIZES:
- 2 \$25.00 PIRATES WELL GIFT CARDS
ALL MOTORCYCLES
WELCOME
- KID FRIENDLY -
RUDE BWOY
RUM TASTING!
7-9PM
SPONSORED BY
POWER SPORTS
Bike Night
EVERY WEDNESDAY
Pirates Well
9477 Alt. A1A Lake Park, #78 33403
www.pirateswell.com

LONE LEGION
MA
BROTHERHOOD
OPEN HOUSE TUESDAY
COME JOIN US FOR A GREAT EVENING!
HOURS: 7:30PM TILL MIDNIGHT
MUSIC, FOOD, BEVERAGES, POOL, DARTS
2950 COMMERCE PARK DR. UNIT F5 BOYNTON BEACH, FL
CONTACT
BUTTER BEAN 561-704-5416
NO WEAPONS, DRUGS OR ATTITUDES
WE RESERVE THE RIGHT TO REFUSE ENTRY

TURBOZ BIKE NIGHT
AT
RALPH'S STAND-UP BAR
CENTER STREET, JUPITER
LAST THURSDAY 7-10PM
LIVE MUSIC
FULL-BAR
BE THERE

**ABATE of FL
Inc.
PALM
BEACH
CHAPTER
MEETINGS**

11:30 AM V.F.W.
Post 4143 at 2404
Broadway, Riviera
Beach 561-844-5718.
From I 95 exit Blue
Heron Blvd. go east to
Broadway (Federal
Hwy., US- 1) turn
right, go south 1 block
the V.F.W. is on the
east side. Look for the
flag. Come for break-
fast and the meeting

2nd Sunday Dec.
3rd Sunday Jan. 19



**SOUTH FLORIDA
PRESIDENTS
COUNCIL EVENTS
DECEMBER**

- 8-Sun SFPC Toys in the Sun Run
- 4th-Sat ALIGATOR ALLEY TOY RUN BIKE DRAWING
- 14th-Sat HERMANDAD MC - ALFREDO MEMORIAL AND TOY RUN
- 14-Sat USMVMC Wreaths Across AMERICA
- 15-Sun WINGS OF GOLD MC MIAMI - TOY RUN
- 25th-Wed Christmas Day

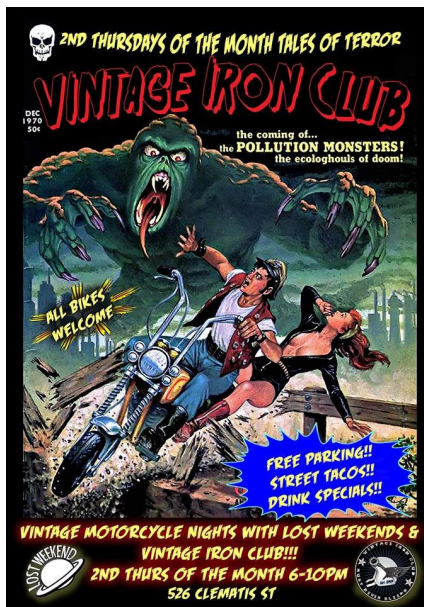

December 2019

Sun Mon Tue Wed Thu Fri Sat

1 Southernmost ABATE Keys Toy Run Polk ABATE Toy Run	2 Skulls @LL Open House	3	4 Gorilla Bob/ Island Jack's, Pirate's Well Lake Park Bike Nights	5 Palm Beach Harley Bike Night Abacoa Black Pistons Open House Howley's Bike Night	6	7 Fly n Wheels Open House
8 ABATE PB Chapter Meeting	9	10 Lone Legion Open House	11 Gorilla Bob/ Island Jack's Pirate's Well Lake Park Bike Nights	12 Vintage Iron Bike Night	13 AOA WPB Open House	14 Wreaths Across Florida ABATE FL State Meeting
15 ABATE PB Annual at Anchor Inn	16	17	18 States LW Open House Gorilla Bob/ Island Jack's Pirate's Well Lake Park Bike Nights	19 Palm Beach Harley Bike Night	20 AOA North Open House	21 Fly n Wheels Open House
22	23	24	25 Gorilla Bob/ Island Jack's Pirate's Well Lake Park Bike Nights	26 Turboz/ Ralph's Bike Night	27	28 Fly n Wheels Open House
29	30	31				

January 2020

Sun	Mon	Tue	Wed	Thu	Fri	Sat
			1 Gorilla Bob/ Island Jack's Pirate's Well Lake Park Bike Nights	2 Palm Beach Harley Bike Night Abacoa Black Pistons Open House Howley's	3	4 Fly n Wheels Open House
5	6	7	8 Gorilla Bob/ Island Jack's Pirate's Well Lake Park Bike Nights	9 Vintage Iron Bike Night	10	11 Fly n Wheels Open House
12	13	14	15 States LW Open House Gorilla Bob/ Island Jack's Pirate's Well Lake Park Bike Nights	16 Palm Beach Harley Bike Night	17	18 Fly n Wheels Open House
19 ABATE PB Chapter Meeting	20	21	22 Gorilla Bob/ Island Jack's Pirate's Well Lake Park Bike Nights	23	24	25 Fly n Wheels Open House
26	27	28	29 Gorilla Bob/ Island Jack's Pirate's Well Lake Park Bike Nights	30 Turboz/ Ralph's Bike Night	31	

DELEGATE REPORT

With our event the next day, Delegates and members will be heading home right after the meeting. So since about 3.5 hour ride likely we will go up Friday and stay overnight.

Tallahassee meeting and Capital ride is quickly coming up so need to get hotel now as room limited. Years ago I attended a bike builder completion in Clearwater as a break to the Capital. This year the event is Feb. 5 to 9 so works as part of Tally trip. It would take 4 hours to get to Monticello so about halfway. The

ABATE of Florida, Inc.



STATE MEETING

Saturday December 14, 2019

Board Meeting Starts @ 12:00PM

Delegate's Meeting Starts @ 2:00 PM

Meetings will be held @ VFW Post 4209
4805 NE 36th Ave Ocala, FL 34479

1. Directions from Equus Inn
2. Head north
3. Turn left toward SW College Rd
4. Turn right onto SW College Rd
5. Use the left 2 lanes to turn left onto S Pine Ave
6. Use the right lane to turn right onto NW 10th St/Bonnie Heath Blvd
7. Turn left onto NE 36th Ave
8. Turn right onto NE 47th Pl
9. Arrive at location: 4805 NE 36th Ave VFW POST 4209

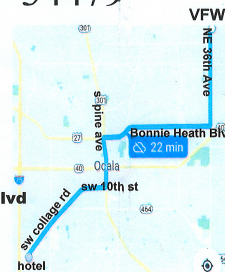

Question ABATE of Florida Inc. 1-386-943-9610

Quality Inn/Equus Inn Hotel
3434 SW College Rd, Ocala, FL 34474 For Reservations Call:(352-854-5633)

For further information contact: ABATE OF FLORIDA, INC. State Office (386) 943-9610

ABATE OF FLORIDA, INC. DOES NOT CONDONE DRINKING AND RIDING.

DONATIONS TO ABATE OF FLORIDA, INC. ARE NOT DEDUCTIBLE FOR FEDERAL INCOME TAX PURPOSES. A COPY OF THE OFFICIAL REGISTRATION AND FINANCIAL INFORMATION MAY BE OBTAINED FROM THE DIVISION OF CONSUMER SERVICES BY CALLING TOLLFREE WITHIN THE STATE. REGISTRATION DOES NOT IMPLY ENDORSEMENT, APPROVAL, OR RECOMMENDATION BY THE STATE. WWW.800HELPLA.COM 1-800-435-7352"

STATE MEETINGS

Host Chapter & Location

2020 State Meetings-

Feb. 9 Monticello

Feb.10 Ride to Capital

Tallahassee Host State

April 11 Southwest

June 13 Vintage

August 8 Lake

Oct. 10 Gulf Coast

Dec. 12 Forest

ABATE of FL Inc.
Palm Beach Chapter

GBNF

Ed "Gunner" Bassett

Frank "Pipes" Cook

Robert "Torch" Lyle

Niurka Crespo

Phil Moore

Michael Steffy

Tom "Ramblin' Man"

Botticelli

Karen Watkins

"Bones" Maurice Clark

Danny Palm

event is Full Throttle Expo 2020 Music Festival and Bike Builder Invitational in Pinellas Park. Event is centered at Bert's Barracuda with Quaker Steak & Lube across street. Right behind is a La Quinta Inn & Suites by Wyndham so it makes everything walkable. Maybe we could make this into a chapter thing to get everyone to the Capital Ride on Feb. 10. I did this as a break Tally trip several years ago and really enjoyed it—now the Harley dealership is there.

Now this past month I went to the same area for St. Pete Bikefest. Now I was not impressed by the event on the Beach as only was music, But at Bert's Barracuda Harley there were lots of vendors and good music, At both places we ran into Zim, his wife and party. He was rocking his ABATE shirt and said would be at our event.



23rd ANNUAL FREEDOM RIGHT MEETING

For More Information ABATE of Florida Inc 1-386-943-9810

State Meeting Sunday, February 9, 2020 at 2:00pm
 State Board Meeting Sunday, February 9 at Noon
 American Legion Hall - 1065 S. Water St., Monticello, FL 32344
 Directions to Hall: Go 2 blocks west of the Opera House on US 90, then turn west on Water Street. Go 1/2 mile to the Legion Hall

"We in America do not have government by the majority. We have government by the majority who participate." ~ Thomas Jefferson

Will you go to Tallahassee to fight for your rights?
 Ride to the Capitol Monday, February 10, 2020
 Kickstands up at 9:00am - Behind the Super 8 in Monticello

Super 8 Monticello: 140 Pafford Rd., Monticello, FL 32336. Phone: 850-997-8888
 Take I-10 to Exit 225 South on US 19. The hotel is located on the West side.

Days Inn Monticello: 44 Woodworth Dr., Monticello, FL 32336. Phone: 850-997-5988. Take I-10 to Exit 225 South on US 19. The hotel is located on the East side.

There are other hotels and campgrounds in the area. The two listed above offer discounts to ABATE members. Please make reservations early.

Membership & Safety Information Available
 ABATE OF FLORIDA, INC. DOES NOT CONDONE DRINKING AND RIDING. DONATIONS TO ABATE OF FLORIDA, INC. ARE NOT DEDUCTIBLE FOR FEDERAL INCOME TAX PURPOSES. A COPY OF THE OFFICIAL REGISTRATION AND FINANCIAL INFORMATION MAY BE OBTAINED FROM THE DIVISION OF CONSUMER SERVICES BY CALLING TOLL-FREE WITHIN THE STATE. REGISTRATION DOES NOT IMPLY ENDORSEMENT, APPROVAL, OR RECOMMENDATION BY THE STATE. WWW.800HELPFLA.COM 1-800-436-7352.

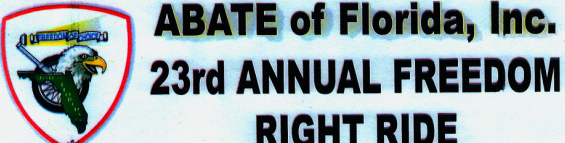
ABATE of Florida, Inc.
23rd ANNUAL FREEDOM RIGHT RIDE

Do you believe in your rights?
 Do you want to keep your rights?
Will you go to Tallahassee to fight for your rights?

RIDE TO THE STATE CAPITOL MONDAY, February 10, 2020

For more information: ABATE of Florida Inc 1-386-943-9810

"We in America do not have government by the majority. We have government by the majority who participate." ~ Thomas Jefferson

Kickstands up at 9:00am - Behind the Super 8 in Monticello

Super 8 Monticello
 140 Pafford Road
 Monticello, FL 32336
 850-997-8888

Membership & Safety Information Available
 ABATE OF FLORIDA, INC. DOES NOT CONDONE DRINKING AND RIDING. DONATIONS TO ABATE OF FLORIDA, INC. ARE NOT DEDUCTIBLE FOR FEDERAL INCOME TAX PURPOSES. A COPY OF THE OFFICIAL REGISTRATION AND FINANCIAL INFORMATION MAY BE OBTAINED FROM THE DIVISION OF CONSUMER SERVICES BY CALLING TOLL-FREE WITHIN THE STATE. REGISTRATION DOES NOT IMPLY ENDORSEMENT, APPROVAL, OR RECOMMENDATION BY THE STATE. WWW.800HELPFLA.COM 1-800-436-7352.

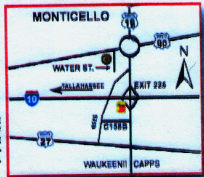

www.abateflorida.com

IF YOU CHOOSE TO RIDE
WITHOUT A HELMET
THANK A.B.A.T.E.
IF YOU WANT TO CONTINUE
TO RIDE WITHOUT A HELMET
JOIN A.B.A.T.E.

*Every decision ABATE makes
effects over 500,000 licensed
motorcyclists in the state of Florida.
Shouldn't your voice be heard?*



South Florida
SPINE & JOINT CENTER
 You want to feel better. We want to get you there.

Personal Injury and Federal Worker's Comp.
 Amanda Stout, Business Development Coordinator
 Office: 833-DrBruce
 Mobile: 305-772-2618
 eMail: amanda@sflspineandjointcenter.com

Locations

Palm Beach Gardens
 4414 Northlake Blvd. Palm Beach Gardens, FL 33411

Port St. Lucie
 6688 US Hwy 1 Port St. Lucie, FL 34952

Delray Beach
 601 N. Congress Ave., #410 Delray Beach, FL 33445

Harold Walters Realtor®
Better Homes and Gardens REAL ESTATE FLORIDA 1
561.948.3412
 Cell/Text: 561.877.6023
 250 W Indiantown Rd, Suite 103 Jupiter, FL 33458
 Harold.Walters@MLS.com
 www.PalmBeachFlorida.com

SUPPORT MEMBERS' BUSINESSES



Deborah Hamby
 Risk Manager

13700 US Highway One, Ste 202B Juno Beach 33408
 Phone: 561.316.3030 | Email: Debbie@ReNuinsurance.com



pampered|chef

Deborah Hamby
 Independent Consultant
 561-847-5331
 pamperedchef.biz/DHamby

SUNCAT



Customs LLC
 Residential • Commercial • Marine

**Installs, Repairs,
 Renovations &
 Fabrications**
Bringing Ideas To Reality
Vincent
561-619-2750

Lauryn Meddows
 (561) 516-1183
 1CraftyCarpentress@gmail.com
 @theCraftyCarpentress
Crafty
 CARPENTRESS
 Picnic Tables and More

New & Used Motorcycle Parts, Accessories
GORILLA MOTORS, INC.
 www.gorillamotors.com
 gorillamotors@yahoo.com
All Makes & Models Mail Order • Export
 Retail • Wholesale
 1547 N. Florida Mango Rd. (561) 684-3953
 Bldg. 19 Cell: 236-0035
 West Palm Beach, FL 33409 Fax: 687-1781

ULTIMATE
Fabrication
 AND
WELDING SERVICES INC.

Mobile Welding - Certified Welders
 All Types of Metal

Ph: 561-844-2377
3560 Investment Lane
Suite 103 B
West Palm Beach FL 33404

MEMBER
ABATE

Licensed & Insured
 With over 20 Years Experience
www.UltimateFabandWeld.com
 sales@ultimatefabandweld.com

.....
 : Precinct Finder (<https://www.pbcelections.org/PrecinctFinder.aspx>) Palm
 : Beach Elections Site - put in your address and get ALL your Election
 : Information and look under My Districts for your representatives.
 : In these sidebars Underlined District # , names link in the online version.
 :

LEGISLATIVE REPORT

DAN "SLOW-MOTION" HENDERSON



PALM BEACH Co. FL House of Representatives

D81 Tina Scott Polsky (D)
850-717-5081 Tallahassee
561-470-2086 Boca/Belle Glade

D82 Mary Lynn Magar (R)
850-717-5082 Tallahassee
772-545-3481 Hove Sound

D85 Rich Roth (R)
850-717-5085 Tallahassee
561-625-5176 Palm Bch Garden

D86 Matt Willhite (D)
850-717-5086 Tallahassee
561-791-4071(2) WPB

D87 David Silvers (D)
850-717-5085 Tallahassee
561-352-4824 West Palm Beach

D88 Al Jacquet (D)
850-717-5088 Tallahassee
561-650-6846 West Palm Bch

D89 Mike Caruso (R)
850-717-5089 Tallahassee
561-750-2396 Boca Raton

D90 Joseph A. Casello (D)
850-717-5090 Tallahassee
561-374-7850 Boynton Bch

D91 Emily Slosberg (D)
850-717-5087 Tallahassee
561-496-5940 Delray Beach

HB 2007 has just passed successfully out of the Transportation and Tourism Appropriations Subcommittee.

I just watched as Doc testified in front of the committee and he gave a great talk about why this is very important. So thank you to all that contacted the members of this committee. The fight continues and I will keep you informed of what is the next step. Darin "Scribe" Brooks Nov. 6

Here is the link to the committee meeting video. HB 2007 starts at around 21:11 into the video

https://www.myfloridahouse.gov/VideoPlayer.aspx?eventID=2443575804_2019111028

WEEKLY ROUNDUP: DESANTIS SPREADS THE BUDGET LOVE

November 22, Dara Kam
Recap and analysis of the week in state government TALLAHASSEE --- A \$1 billion boost for public schools and teachers. Almost \$100 million in new money for people with intellectual and developmental disabilities. And hundreds of millions of dollars to clean up and protect the state's waters

Those are just a few of the big-ticket items on Gov. Ron DeSantis' wish list, as he rolled out his second state spending proposal this week.

The Republican governor laid out a \$91.4 billion budget --- the biggest in state history --- for lawmakers to consider during the 2020 legislative session, which begins Jan. 14.

Palm Beach County FL Senators

D25 Gayle Harrell (R)
850-487-5025 Tallahassee
772-221-4019 Stuart

D29 Kevin Rader (D)
850-487-5029 Tallahassee
561-443-8170 Boca Raton

D30 Bobby Powell (D)
850-487-500 Tallahassee
561-650-6880 WP Bch

D31 Lori Berman (D)
850-487-5031 Tallahassee
561-292-6014 Boynton

FEDERAL U.S. Senators

[Marco Rubio](#)
[Rick Scott](#)

U.S. HOUSE

District 18
[Brian Mast \(R\)](#)

District 20
[Alcee Hastings](#)

District 21
[Lois Frankel](#)

District 22
[Ted Deutch](#)

There's something for almost everyone in the governor's election-year plan.

The cornerstone of DeSantis' budget is an education-spending boost that includes a minimum \$47,500 salary for teachers and a replacement for the much-maligned "Best and Brightest" bonus program.

He also wants lawmakers to unfold the state's wallet --- to the tune of more than \$100 million --- to attract and keep workers in the state's prison system.

At the same time DeSantis is seeking dollars for areas of the budget he deems worthy, the former congressman put legislators on notice: Cut back on the "earmarks."

The governor used the Washington, D.C. description for what are known in the Florida Capitol as "member projects," budget line items for things such as water projects, libraries and courthouse repairs.

Although the details of any massive spending plan can result in a collective eye-roll, former President George W. Bush managed to inject some levity into the subject.

"It's clearly a budget," Bush once infamously said. "It's got a lot of numbers in it."

ALL ABOUT THE BENJAMINS

DeSantis' proposed \$1 billion injection into Florida's public education system in the upcoming fiscal year would largely go toward pay increases as the state deals with a teacher shortage.

After dubbing next year the "Year of the Teacher," DeSantis has made two major teacher-compensation packages the centerpiece of his education spending plan for the 2020-2021 fiscal year.

The governor's overall \$26.99 billion proposed education budget --- the second-biggest slice of his \$91.4 billion spending plan --- also includes funding issues such as school security and mental-health services. The \$26.99 billion total includes public schools and higher education.

"Of course, as many of you know, education has been probably our top issue that we have been talking about in the last couple of months," DeSantis told reporters Monday, when he unveiled the budget proposal.

The proposal is an initial step as lawmakers prepare to negotiate a 2020-2021 budget during the upcoming legislative session.

The governor's biggest teacher-pay proposal would require the Legislature to set aside \$603 million to set minimum salaries of classroom teachers at \$47,500 a year.

Also, the governor is pitching a new \$300 million bonus program for classroom teachers and principals. DeSantis wants the program to replace the controversial "Best and Brightest" program, which the Legislature created in 2015.

"We are getting rid of the Best and Brightest, which has gone through these iterations, and I think it was well-intentioned, but I don't know if it ever hit the mark," DeSantis said.

DeSantis also wants to provide \$100 million to schools in mental-health spending --- a \$25 million boost over the current year's amount. The extra dollars would be used to hire more service providers, according to the proposed budget.

House Speaker Jose Oliva, R-Miami Lakes, issued a statement Monday that described DeSantis' overall budget recommendations as "encouraging." But he also said the "the details of his ambitious teacher-pay program remain obscure --- not a small matter."

LOCKED AND LOADED Florida, a long-time model for National Rifle Association-backed laws, has been castigated as the "gunshine state" by critics of the gun rights organization.

But in a twist, the NRA last year challenged a state law quickly enacted in response to a horrific mass shooting at Marjory Stoneman Douglas High School in Parkland that left 14 students and three faculty members dead.

The sweeping school-safety law included a provision that raised the minimum age to purchase rifles and other long-guns in Florida from 18 to 21. Immediately after then-Gov. Rick Scott signed the legislation, the NRA filed a federal lawsuit challenging the constitutionality of the age restriction.

The federal case has languished for more than a year, while the NRA sought to keep secret the identities of two plaintiffs.

But, in an effort to reignite the lawsuit, the NRA last week abandoned its effort to use pseudonyms for plaintiffs “Jane Doe” and “John Doe.” It filed an amended 12-page complaint Tuesday that named Radford Fant of Duval County, “a law-abiding, responsible citizen between the ages of 18 and 21,” as a new plaintiff.

The gun-rights group alleges that the age restriction is an unconstitutional violation of people’s Second Amendment right to “purchase firearms to defend themselves, their families, and their homes.”

Radford Fant is the son of former state Rep. Jay Fant, R-Jacksonville, Marion Hammer, the NRA’s Florida lobbyist and a former president of the national group, confirmed Friday.

Also this week, lawyers for Attorney General Ashley Moody, whose office is representing the state, and the NRA filed proposed deadlines in the case that could lead to a trial next summer. “Getting the primary case moving so the constitutional rights of Florida’s young adults can be restored is a top priority with NRA,” Hammer told The News Service of Florida in an email Wednesday.

STORY OF THE WEEK: Gov. Ron DeSantis rolled out a proposed \$91.4 billion budget for lawmakers to consider in the upcoming 2020 legislative session, which begins Jan. 14.

QUOTE OF THE WEEK: “Given that this was approved by a legislature that was majority Democrat and signed into law by a Democrat governor in 1951, it is difficult to see how it is discriminatory to Democrats. This is purely motivated by politics and has no legal merit.” --- Gov. Ron DeSantis’ spokeswoman Helen Ferré, following the state’s appeal of a federal court ruling that struck down as unconstitutional a Florida law requiring candidates who are in the same party as the governor to be listed first on the ballot.

HOUSE, SENATE PANELS SET TO MEET IN DECEMBER November 19, NSF Staff

With the Jan. 14 start of the 2020 legislative session approaching, the House and Senate have set aside four days for committee meetings in December. Both chambers have scheduled meetings from Dec. 9 through Dec. 12. The House Appropriations Committee is slated to meet Dec. 10, while the Senate Appropriations Committee is scheduled for Dec. 12. Also, House appropriations subcommittee meetings are sprinkled throughout the week, while Senate appropriations subcommittees are slated for Dec. 11. The appropriations meetings could be the first opportunity for lawmakers to receive presentations on Gov. Ron DeSantis’ proposed \$91.4 billion budget for the fiscal year that starts July 1. Lawmakers will consider DeSantis’ proposal as they negotiate a budget during the legislative session.

STATE FIGHTS CITIES, COUNTIES ON GUN LAW November 25, Jim Saunders

TALLAHASSEE --- Pointing to a “hierarchical relationship” with local governments, the state late Friday asked an appeals court to uphold a 2011 law that has threatened tough penalties if city and county officials approve gun regulations.

Lawyers in the offices of Attorney General Ashley Moody and Gov. Ron DeSantis filed a 42-page brief arguing that the 1st District Court of Appeal should overturn a circuit judge’s ruling that said parts of the law were unconstitutional.

Florida since 1987 has barred cities and counties from passing regulations that are stricter than state firearms laws, and the penalties in the 2011 law were designed to strengthen that “preemption.” The law, for example, could lead to local officials facing \$5,000 fines and potential removal from office for passing gun regulations.

The brief filed Friday cited a “hierarchical relationship” between the state and local governments and said the Florida Constitution “subjugates local governments’ authority to that of the Florida Legislature.” “The trial court’s decision is premised on unsupported theories of immunity inconsistent with the constitutional supremacy of the state’s authority over its counties and municipalities,” the brief said. “If al-

lowed to stand, the decision will not only invite the development of a patchwork regulatory regime in the area of firearms but also render the Legislature impotent to deter power grabs by local officials in other areas.”

But as an indication of the potential legal stakes of the case, the Florida League of Cities and the Florida Association of Counties on Monday filed a document requesting approval to submit a friend-of-the-court brief on behalf of the dozens of local governments and officials challenging the law.

“The resolution of the question on appeal is of great importance to the League and FAC (Florida Association of Counties) and their memberships of diverse local governmental entities across the state of Florida,” the request said. “A determination that the penalty provisions are constitutional increases the threat of liability at significant cost to local government officials and will also have a chilling effect on individuals desiring to serve in local government.”

Local governments and officials filed three lawsuits challenging the 2011 law after last year’s mass shooting at Marjory Stoneman Douglas High School in Parkland that killed 17 people. The lawsuits were ultimately consolidated in Leon County circuit court.

Attorneys for the local governments wrote in a February court document that city and county officials had been urged to take actions after the Marjory Stoneman Douglas shooting. Those requests involved such things as requiring procedures or documentation to ensure compliance with background checks and waiting periods for gun purchases and requiring reporting of failed background checks.

But the attorneys said local governments refrained from going ahead with the proposals because of the potential penalties in state law. Along with officials facing the possibility of fines and removal from office, the law would allow members of the public and organizations to receive damages up to \$100,000 and attorney fees if they successfully sue local governments for improper gun regulations.

Leon County Circuit Judge Charles Dodson in July found parts of the law unconstitutional, citing issues related to “legislative immunity,” which protects local government officials in their decision-making processes. He also pointed to the constitutional separation of powers, as judges could be asked to rule on penalizing local officials.

“Because local governments must have what amount to small legislatures, and because courts cannot interfere in legislative processes, neither this court, nor any other court in Florida, can enforce the civil penalty provisions (of the law) against local legislators,” Dodson wrote.

But the attorneys for Moody and DeSantis rejected such arguments in Friday’s brief, repeatedly citing the state’s authority over local governments.

“The state’s position is that the Legislature may penalize local officials for acting outside the scope of their authority because there is no ‘separation of powers’ doctrine that bars the Legislature from holding them accountable for their official actions,” the brief said.

Attorneys for the cities and counties will file a brief at the appeals court within the next month. But when the state began moving forward with the appeal in July, Jamie Cole, the lead attorney for the local governments, said he expected Dodson’s ruling to stand.

“Judge Dodson’s decision was well-reasoned, well-written and supported by decisions from the U.S. Supreme Court, Florida Supreme Court and Florida’s district courts of appeal,” Cole said at the time.

DESANTIS BUDGET WOULD TRIM ‘EARMARKS’ November 19, Jim Turner

TALLAHASSEE --- State lawmakers got another message to expect a lean year for bringing home budget bacon.

Gov. Ron DeSantis, a former congressman, used a Washington, D.C. term Monday in saying “earmarks” would need to be cut by \$84.8 million to help pay for his proposed record \$91.4 billion budget.

While described as targeting “recurring” requests, mostly in education areas of the budget, De-

Santis' proposed cuts could leave space for about \$200 million in spending from among the more than \$1 billion that has already been pitched by legislators for local programs and projects.

Such spending is often derided as pork or, in a Tallahassee term, "turkeys" because of how it gets into the budget or its statewide relevance.

DeSantis' proposed reduction in earmarks came after House and Senate budget leaders urged "restraint" from lawmakers in filing appropriations requests. State economists have forecast an economic slowdown that will result in Florida bringing in about \$867 million less in revenue over two years than previously projected.

On Monday, House Speaker Jose Oliva used the phrase "fiscal restraint" in praising DeSantis' overall budget proposal, which is an initial step as lawmakers prepare to negotiate a 2020-2021 spending plan during the upcoming legislative session.

Meanwhile, Senate President Bill Galvano issued a statement noting that his chamber will use the final pre-session committee week in December to hear formal presentations on the governor's budget proposal. Galvano said he's also waiting for updated calculations about state revenues and costs from economists.

"We are closely monitoring the next round of consensus estimating conferences, which will provide important updates in terms of anticipated needs in each area of the budget," Galvano wrote. "We are also anticipating a new general revenue estimate, which will indicate if there has been a change in the amount of revenue available to meet those needs."

As of Tuesday morning, House members had filed 952 appropriations proposals, collectively totaling \$1.29 billion.

In the Senate, 341 proposals had been submitted, totaling \$421 million.

The proposals range from a high of \$50 million that Rep. Randy Fine, R-Palm Bay, is seeking for water-quality improvements in Brevard County (HB 2053) to a \$10,000 ask by Rep. Mike Gottlieb, D-Davie, for Art in the Workplace of Broward County (HB 2021).

More than one-third of the proposals that have been filed seek \$1 million or more.

Most of the spending proposals will be scrapped by the time House and Senate leaders finish negotiating a budget in March.

But in five pre-session committee weeks that have been held in advance of the 2020 session, which begins Jan. 14, House panels backed 207 of the bills, which collectively seek \$239.2 million. None drew a vote in opposition.

Republicans, who control the House, accounted for 150 of the bills that have moved forward, worth a total of \$204.6 million. Democrats have seen 57 proposals, collectively worth \$34.6 million, draw House subcommittee endorsements.

The proposals by Fine and Gottlieb were among those that got support.

For the current fiscal year that started July 1, the \$90.98 budget contains about \$270 million for 440 local projects and programs.

That spending was culled from more than 1,600 House proposals and a near equal number of Senate proposals that were submitted for the 2019 legislative session. House members were looking for \$3.7 billion to bring home. Senators had sought more than \$3.2 billion.

The numbers were partially inflated by Panhandle lawmakers seeking hundreds of millions of dollars in aid for communities devastated by Hurricane Michael in 2018.

Still, nearly 600 proposals, worth a combined \$400 million, were included in the spending plan legislators delivered to DeSantis in May. DeSantis used his line-item veto to slash more than 160 proposals, worth \$130 million.

STATE APPEALS BALLOT ORDER RULING November 18, Dara Kam

TALLAHASSEE --- After a string of narrow victories by Republicans in Florida, Gov. Ron DeSantis' administration is quickly challenging a court decision that could help Democrats in next year's presidential election.

U.S. District Judge Mark Walker, siding with state and national Democrats, on Friday struck down a decades-old state law requiring candidates who are in the same party as the governor to be listed first on the ballot.

The Republican governor's administration quickly filed a notice of appealing the decision.

Walker found the law "imposes a discriminatory burden on plaintiffs' voting rights which is not of the same magnitude as entirely denying plaintiffs the franchise but is not negligible either."

The effect of being the first candidate listed on the ballot --- known as the "primacy effect" vote, the "windfall vote" or the "donkey vote" --- is especially meaningful in Florida, where narrow margins are common in statewide contests.

A year ago, DeSantis defeated Democratic gubernatorial candidate Andrew Gillum by fewer than 33,000 votes, or four-tenths of a percentage point. And the race between former Democratic U.S. Sen. Bill Nelson and former Gov. Rick Scott, a Republican, was even closer. After a statewide recount, Scott emerged the victor in the Senate race by about 10,000 votes, or two-tenths of a percentage point.

In 2016, Trump edged out Democratic challenger Hillary Clinton by about 113,000 votes, or 1.2 percentage points, capturing Florida's critical 29 electoral votes.

The margins in those elections was smaller than the advantage first-listed candidates have historically gained in Florida, according to political scientist Jon Krosnick's analysis of elections in the state from 1978 through 2016.

Krosnick, an expert witness for the plaintiffs in the federal lawsuit, found that candidates who appear first have historically gained an average advantage of 5 percentage points due to their ballot position, an effect that has less than a 1 percent probability of occurring by chance. The advantage is even greater when just two candidates are in the race, Krosnick found.

As is typical, Secretary of State Laurel Lee's notice of appeal Friday did not elaborate on the DeSantis administration's reasons for appealing Walker's decision.

But DeSantis spokeswoman Helen Ferré told The News Service of Florida Monday that the judge was "questioning the legality of a law that is nearly 70 years old."

"Given that this was approved by a legislature that was majority Democrat and signed into law by a Democrat governor in 1951, it is difficult to see how it is discriminatory to Democrats. This is purely motivated by politics and has no legal merit," she said in an email.

Florida's ballot-position law was enacted 68 years ago, when Democrats controlled the governor's office and the Legislature.

But with narrow margins in many high-profile elections, who is listed first on the ballot is more important than ever, Democrats argued in the lawsuit.

While the advantage of appearing first on the ballot "is (a) relatively small percentage taken in isolation," Walker agreed, "the records of Florida's elections which are before this court demonstrate it is more than the margin of victory or defeat in a great many elections in Florida."

Lee had argued that the ballot order provision is necessary because it is "upholding the policy choices of Florida duly-elected representatives."

But Walker disagreed.

"If the Florida Legislature adopts an unconstitutional law, Florida's interest in having made that legislative choice will not render that law constitutional," he wrote.

The federal judge, who has frequently ruled against the state in election-related challenges, issued a stern warning to Lee and set a tight schedule for her to comply with his order.

He gave Lee two weeks to inform county supervisors of elections in writing that the ballot order law had been declared unconstitutional and ordered her to come up with an alternative process. And Walker gave Lee three weeks to file a “notice of compliance” with the court. The judge also ordered Lee to inform him when the state adopts a new ballot order “scheme,” which he left up to Florida officials.

Since the appeal was filed, Walker will have to decide whether to put his ruling on hold until the appeal has been decided or, possibly, until the case has been finalized. Such a delay could threaten Democrats’ opportunity to undo the GOP advantage on next year’s ballot.

But Marc Elias --- who represented the Democratic National Committee, the Democratic Governors Association, the Democratic Legislative Campaign Committee, Priorities USA, the Democratic Congressional Campaign Committee and other plaintiffs in the case --- told the News Service he has “every expectation that the citizens of Florida will have a new fair ballot order system in place for the 2020 elections.”

Elias, who argued that the state law enables Republicans to put an invisible “thumb ... on the scale” of elections, recently filed similar lawsuits in Arizona, Texas and Georgia.

The legal challenges are part of Democrats’ attacks on elections laws in so-called red states in an effort to gain traction prior to next year’s presidential contest.

“Everyone recognizes that the goal here is to prevent one party from enjoying an unfair advantage over another,” Elias said.

In his 74-page order Friday, Walker said a majority of states do not use the same system as Florida. He also acknowledged the ballot order is not the only reason a candidate wins or loses an election.

“But although no single raindrop bursts a dam, and a single small transaction rare is the sole cause of a bankruptcy, the dam still fails and the debtor becomes insolvent. Similarly, candidate name order effects are not the only reason elections are won and lost, but they do contribute substantially to candidates’ successes or failures at the polls,” he wrote.

“By systematically awarding a statistically significant advantage to the candidates of the party in power, Florida’s ballot order scheme takes a side in partisan elections,” the judge wrote.

BACKROOM BRIEFING: A COMMITTEE WEEK, MINUS THE COMMITTEES

November 14, Ana Ceballos Jim Turner Weekly political notes from The News Service of Florida

TALLAHASSEE --- About one-sixth of state House members had no scheduled committee meetings this week. Another third had a single committee meeting.

And, while it was a holiday-shortened week, the dearth of meetings wasn’t unique in the House as lawmakers prepare for the Jan. 14 start of the 2020 legislative session.

Democratic Rep. Anna Eskamani, without any of her committees scheduled to meet, made the trip from Orlando to Tallahassee for bill presentations and other activities around the Capitol. But she expressed a desire to see more legislation get considered.

“I’d like to have just informational sessions on different tax policy ideas. We’ve had only one Ways and Means Committee so far, and I would argue that’s one of the most important committees in the Florida Legislature,” Eskamani said Tuesday before Democrats held a press conference on climate change. “For the public watching, it’s a reflection of the things happening behind the scenes and not necessarily legislation happening before the public’s watchful eyes,”

Rep. David Smith, R-Winter Springs, said he made sure to get leadership support for his three primary proposals filed for the upcoming session.

“Committees aren’t meeting, but my bills are moving,” Smith said Wednesday.

The Legislature each year holds a series of committee weeks to begin working on legislation

before the regular session starts. Lawmakers are assigned to varying numbers of full committees and subcommittees.

Overall, 22 representatives --- not including the House speaker, who isn't assigned to committees --- didn't have meetings this week to hear presentations, consider appropriations bills or decide on a handful of other proposals put forward by their colleagues.

Another 43 lawmakers had one committee meeting, meaning more than half of the 120 House members had one or no meetings on tap for the week.

Last week, 19 House members had none of their assigned committees meet. Forty-six had a single committee meeting.

Rep. Evan Jenne, a Dania Beach Democrat who has had just one of his committees meet since September, said no one should be surprised.

"Speaker (Jose) Oliva was very up front when he started," Jenne said. "He wanted to pass as few bills as humanly possible. He has not hid this from anyone. It is a real philosophy of government. It's not one that I particularly agree with. But it is a real philosophy when it comes to government, and he's been completely open and forthright about what he intended on doing."

The speaker's office did not reply to a request for comment.

A fierce small-government proponent, Oliva, R-Miami Lakes, urged "restraint" in governing when he took control of the House in November 2018.

The Senate has been a little more active with committee meetings.

Members of the Senate had on average 2.35 meetings this week, down slightly from 2.4 last week.

The most active week for the Senate, with members having an average of 3.45 meetings, was the week of Oct. 21, which included the entire body twice convening during a special session on the removal of Scott Israel as Broward County sheriff.

On average, House members had 1.45 meetings this week and 1.42 last week, down from an average of two meetings during the two committee weeks in October.

SENATE LEADERSHIP LINEUP

Before the dust could even settle on Sen. Kathleen Passidomo's selection to become Senate president in 2022, whispers filled the Capitol's hallways about who would succeed her.

Passidomo emerged the winner Tuesday afternoon in a mostly behind-the-scenes race to become Senate president after the 2022 elections and lead the chamber for two years. By Wednesday afternoon, Republicans Ben Albritton and Manny Diaz Jr. had confirmed to The News Service of Florida they are running to be next in line.

Albritton and Diaz want to serve as president during the 2025 and 2026 legislative sessions, assuming Republicans maintain control of the Senate.

But first, Albritton and Diaz need to secure "pledge cards," which are an indication of support from other senators.

"We have earned a huge amount of support, goodwill, and trust in our caucus. I am deeply blessed by it all," Albritton, R-Wauchula, said in a statement.

"I am actively talking to members," Diaz, R-Hialeah, told the News Service on Wednesday, noting that he sees "quick momentum" in his legislative face-off with Albritton. "I have cards in my possession."

Presiding officers have often hailed from districts with little fear of an election challenge. Diaz resides in an increasingly Democratic Miami-Dade County, which could make his path to the Senate presidency slightly bumpier.

Albritton, who represents a deep red region, is less likely to face a contentious challenge.

ABATE of FL Inc. Palm Beach Chapter Minutes Nov.17

Meeting of Abate Palm Beach Chapter was held at The VFW Post, 2404 Broadway Ave, Riviera Beach, FL 33404,

Meeting Called to Order at 11:40 A.M. 13 Members Present _1 Guests Present

Meeting started with the Pledge of Allegiance and a moment of silence.

President: Curtis Ride SAFE and ALERT. Our event is now at Anchor Inn on Hypoluxo west of 95. Starts at 2 setup at noon. Turkey Toy Run is Nov.23 so will meet to ride. December chapter meeting will be the SECOND Sunday the 8th to go over event prep. ALL rifle drawing tickets and money need to be turned in to go to December State meeting.

Vice President: LB Need volunteers to work the event.

Secretary: Florie excused, SI Mo sat in Asked if anyone has any additions, corrections or objections to last month's meeting minutes as published in chapter newsletter. There were none.

Treasurer: Suzanne Funds getting low. Need a great turnout for our event, get the word out

Membership: Vince absent, Harold excused More ADD beneficiary cards collected, Half Pint send those previous collected to State office

Sergeant At Arms: Petee Inventory time. Will be event security so needs lots of helpers

Safety: Slo-Mo Weather has been bad for events but going to try to get to more to promote our event

Delegate Report: Slo-Mo & Snooze State meeting is December 14, day before our event so we return right after. Drawing tickets and money MUST to turn in at the meeting

Legislative: Slo-Mo HB2007 Safety money passed committee so great news. You can watch Doc talk to the committee. Read full report page

Public Relations: Slo-Mo As soon as all paperwork is complete, will promote our event. On Facebook everyone should share. Suzanne is working to streamline the flyer. We need everyone to get the word out.

Newsletter: Slo-Mo Getting the DEcember issue out early so need everything in by Thanksgiving so can get printed to promote

Products: Kathy absent

Old Business: Vote on to continue State rifle drawing, chapter yes. Our Event covered previous. Attendance for November Turkey toy Run.

New Business: Suzanne will replace Vince for membership with Harold assisting for renewals. Products trustee is vacant.

Good of the Order: Dec. 14 Wreaths Across America at South Florida National Cemetery, 441/7 Lake Worth. Ceremony starts at 12:00 PM come early so you get a parking place. Had a Guest speaker speak of the Reel Time Fishing Program, hopes to work with us. Feb. is a vets program. Nighthawk is now in the iguana hunting business
 Door prize PB Harley t-shirt won by Debbie "Foxybabe". She also won the 50/50

Adjournment: Meeting adjourned at 1:20.

After meeting several of board went to the Anchor Inn to go over event plans.



Reel Time USA
 Catch and Release Challenge
 Will you catch & release the most Largemouth Bass?

- ✓ Win awesome prizes (listed on our Website) & National recognition
- ✓ Fish from anywhere in the United States
- ✓ \$20 Entry Fee*
 \$10 Senior Citizens & Veterans, \$5 for Teens & Kids
- ✓ Help raise awareness and funds for Multiple Sclerosis Society

SATURDAY, APRIL 25TH, 2020
 *OVER 50 DIVISIONS: KAYAK, BOAT, LAND, LIVE BAIT, ARTIFICIAL, FLY, SENIOR CITIZEN, ADULTS, TEENS, CHILDREN & OUR VETERANS

For more information or to Sign up, go to: www.reeltimeusa.com
 *For every entry, \$1.00 will be donated to MS Society

Palm Beach Motorcyclists Toys For Tots, Inc.

37th Annual
Bill's Bike's Memorial Toy Run

ADMISSION ONE OR MORE NEW TOYS PER RIDER or \$10. Per Person
 Toy Presentation at Dreher Park

TOYS FOR TOTS

2019 SUNDAY December 15 Rain or Shine

Motorcycle Parade Leaves at 12 NOON From S.F. Fair Grounds

Music • Food • Drinks & Vendors
 Grand Marshal Chief Deputy Mike Gauger

Live Music
Capt Nasty And JCB Blues
 Coca-Cola

Paul The Sound Guy Audio Provider
(561) 424-1981
www.pbtovrun.com

WHY JOIN ABATE OF FLORIDA, INC.?

ABATE is a non-profit Motorcycle Rights Organization whose cause is to EDUCATE the government, motorcyclists and the general public on freedom, rights, road safety, and awareness of motorcycles on the road.

REQUIREMENTS—must be at least 18 years of age. In does not matter what you or even if you ride. You can be an independent or member of a club or association. All are welcome at meetings.

JOIN FOR THE CAUSE. Everything is voluntary, we understand work and family comes first. We hope you can help in any small way, vote and spread the word.

BENEFITS Your money is used to provide a lobbyist to the state and federal government to watch for our rights and freedom. The State *MasterLink* newsletter every 2 months we bring back from State meeting or read it online. The chapter newsletter is available online at palmbeach.abateflorida.com so is in color, with active Internet links and zoomable. Members get free classified ads in our newsletters.

INSURANCE As an active member you have a \$4,000 **Accidental Death and Dismemberment** policy from American Income Life. You will get a card in the mail from state office to register your beneficiary for ADD insurance. Do NOT mail it, just be sure your family knows about the policy. If you send it in and they try to meet to sell you more so only if you are interested in more insurance. If they bother you contact our State Office to have it stopped. You can mail to the office as Registered letter to have it done when you family notifies. Be sure to renew in time so are always covered! It does not have to be a motorcycle accident.

MOTORCYCLE INSURANCE Palm Beach Chapter members can get an insurance discount with Leslie Kay Progressive insurance company. Contact them for a quote 1-866-367-1788 www.LeslieKays.com The \$3000 accessory package is normal. The State has arranged with Coastal Insurance Company to offer members up to 10% discount and \$3000 parts and accessories coverage. They are at 190 Hwy A1A Suite, Satellite Beach FL . Agent Doug Guido's phone is 888-596-2453. So these are two more options to compare with your company

PRIVACY Your email, address and phone are never given out to anyone except State/Chapter executive board.

EMAILINGS you can be added to a mass mailing which you can opt to be removed at end of email. Usually only do twice a month to let you know our Newsletter is online and remind you of chapter meetings. Local events are included and sometimes urgent matters may be included. No one will see your email **PHONE TEXT** another way to communicate with members. Your phone number may be added to our text alert system To change or add the chapter email is palmbeach.abateflorida@gmail.com Our website is palmbeach.abateflorida.com

We have a Facebook page <https://www.facebook.com/AbatePalmBeachChapter>

Mail: **ABATE - Palm Beach Chapter, P.O. Box 530944, Lake Park, FL 33403**

Another benefit of chapter membership in ABATE of FL Palm Beach is having a free business card in newsletter and free newsletter classified for items to sell or acquire. Support your brothers and sisters when possible, Besides a \$4.000 ADD insurance policy, discount Leslie Kay insurance, we are looking into other benefits for members. We are always in need of more paid advertisers so find any business to benefit from our low rates and support our newsletter and chapter.

A.D.D. INSURANCE POLICY UPDATE

We all realize the \$4,000 Accidental Death and Dismemberment insurance policy if one of the best benefits of being an ABATE member. That is one reason to keep your membership up to date. You MUST name someone to get the money in case of death to prevent taxes and being in probate court. So when you receive the yellow card mailed from our state office, you can complete it and mail to insurance company. Most likely an agent will contact you even if you said not to. If they do be, SURE to get their name and number upfront. They do NOT need to visit you even to deliver the certificate. If they insist or get push, contact ABATE of FL. main office and report it but you MUST have the agents' name and number for action to be taken. Otherwise you may just return the completed yellow card to ABATE to have on file. Then be sure your survivors know to contact ABATE for the benefits.

STATE OFFICE: ABATE OF Florida, Inc. PO Box 2520, Deland, FL 32721-2520

Phone: (386) 943-9610 Fax: same Email: flabate@bellsouth.net



ABATE OF FLORIDA INC. PALM BEACH CHAPTER MEMBERSHIP APPLICATION



Membership Dues: \$20 for 1 year or \$600 for Life Membership per person

Fill out form, print, sign, and attach your check or money order and mail to:

ABATE — Palm Beach Chapter

PO Box 530944 Lake Park FL 33403

ALL APPLICATIONS ARE SUBJECT TO APPROVAL

PLEASE PRINT CLEARLY Will Palm Beach Chapter be your HOME voting Chapter
NEW Member: Year or Life Renew: Transfer: Address Change:

First : Last : Road :

Address:

City: State: Zip (full): -

Phone: Cell: Text notification Yes No

Email for News Alerts

Registered Voter? Yes No State House: State Senate: US Dist:

How can you best help ABATE? Time, Labor, Money, Other

State newsletter the *MasterLink* every other month online and our Chapter newsletter
The Chrome Chronicles is online at start of month in color with active Links.

MEMBERSHIPS FEE \$

ALL APPLICATIONS ARE SUBJECT TO APPROVAL

SIGNATURE Date:

MEMBERSHIP CARD / PATCHES CAN BE GOTTEN AT CHAPTER MEETING (on the third Sunday of Month usually) OR MAILED WITHIN 30 DAYS. LIFE CARD MAY TAKE LONGER AS PICKED UP AT STATE MEETINGS EVERY OTHER MONTH



Next Palm Beach Chapter Meeting VFW POST 4143
2ND Sunday Dec. 8 , 2019 11:30 am

Directions: 2404 Broadway (US1), Riviera Beach - Exit I-95 at Blue Heron Blvd, go east to Broadway (US1) turn south and is 1 block on east

GOALS & PURPOSES OF ABATE

To print a newsletter to keep all bikers informed with regard to legislative actions and events around the state and throughout the country.

To become a powerful and viable political force in legislative matters concerning all motorcyclists rights.

To provide a lobbyist to represent ABATE of Florida, Inc. on the state and national level.

To promote voter registration and motivate members to write their legislators.

To promote safe riding habits without infringing on individual rights.

To educate the public about motorcycle awareness.